

# WATERFALL AUDIO

SOUND DESIGNERS



MADE IN FRANCE



## DATA SHEET

### ELORA EVO SHELF STAND

#### KEY POINTS

- Aluminium shelf stand
- Compatible with Elora Evo Center and Elora Evo L/R

## ELORA EVO L/R AND CENTER

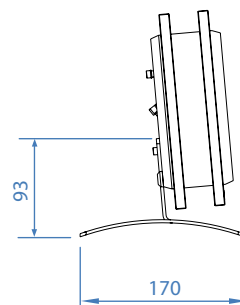
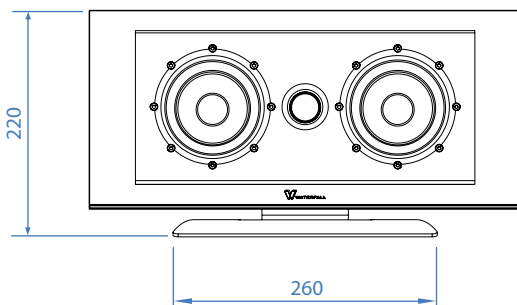
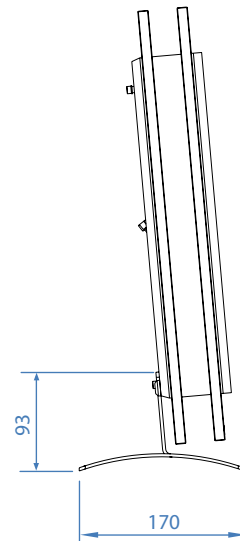
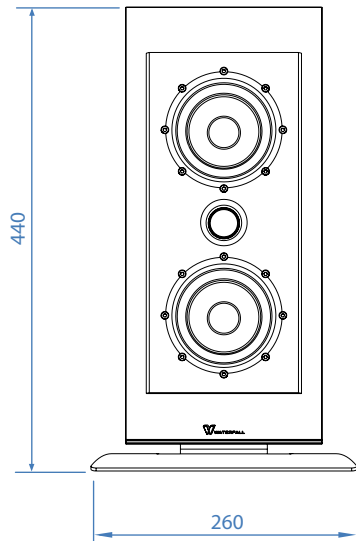

### TECHNICAL DETAILS

TYPE	Support accessory / shelf stand
DIMENSIONS (width x depth x height in mm) (approx. inches)	260 x 170 x 93 / 10.24" x 6.69" x 3.66"
WEIGHT Kg (approx. lbs.)	0.3 kg / 0.66 lbs

### WATERFALL AUDIO

ZA les praderies - 83 570 Carcès - France  
[waterfallaudio.com](http://waterfallaudio.com)

Made in France. 5 years warranty on speakers, 2 years warranty on amplifiers (parts & service).  
We operate a policy of continuous improvement and reserve the right to amend designs and specifications without prior notice.

 All drivers are developed and manufactured by ATOHM (France).